

MESMEC

More from raw

MESMEC OPEN MIXERS

OMX 1500 – OMX 5500 L

Mesmec have over 30 years of experience in design and manufacturing of high quality Mixers to the Food Industry. The most common applications can be found in the Meat, Poultry, Fish and Pet Food industries. Our Mixers are recognized as robust, easy to operate and with very high cleanability. We use standard components with the newest technology to secure availability of spare parts globally.

The Mesmec OMX-series is an open Mixer type which is intended for mainly mixing of low viscosity products where neither cooling or heating is needed - in order to achieve a low cost of ownership! The OMX-series is delivered in sizes ranging from 1500 L up-to 5000 L as standard with a wide variety of options. You are welcome to get familiar with our know-how and technology!

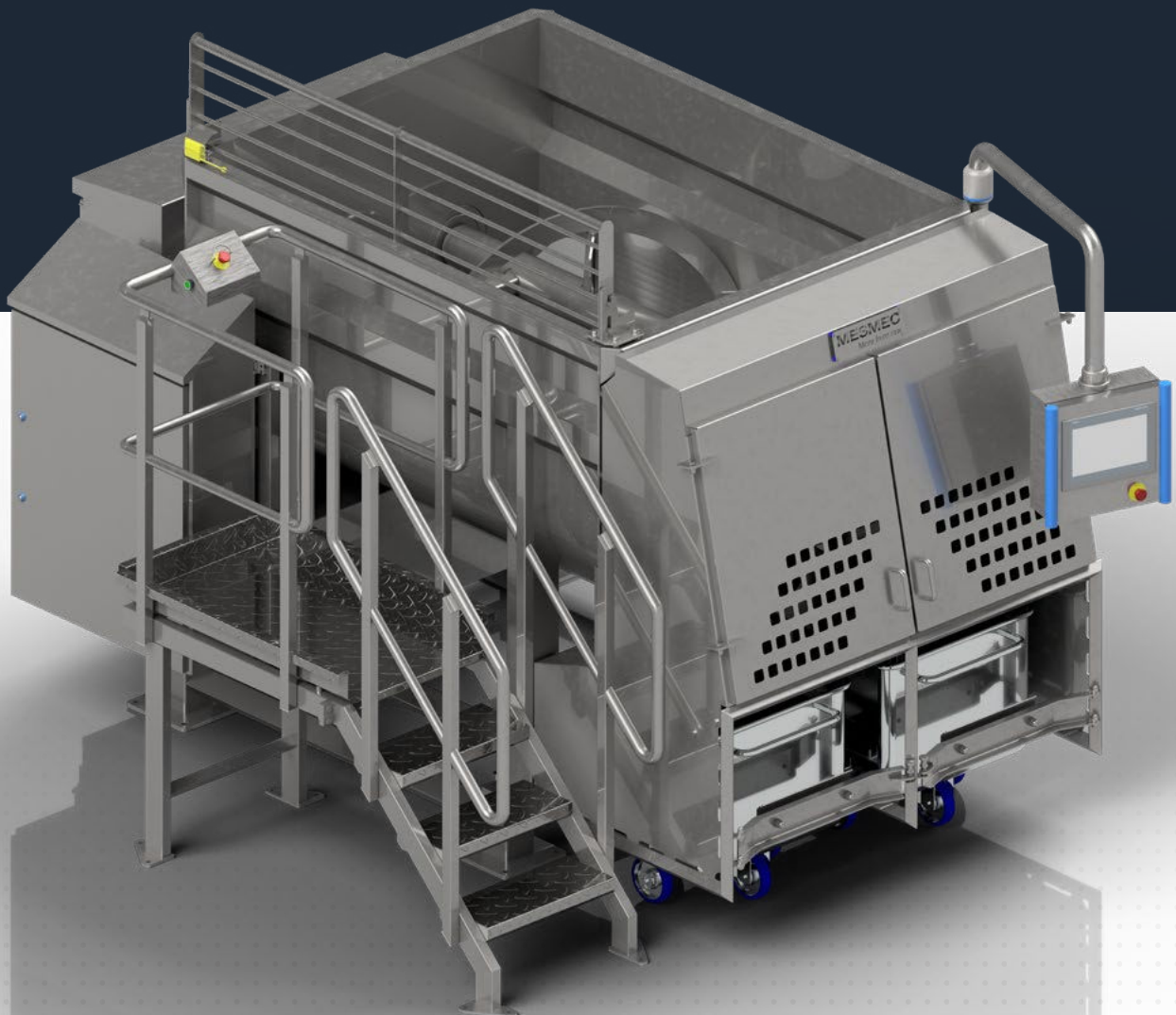

FEATURES AND OPTIONS

- Single shaft or double shaft
- Paddle or spiral mixing wings
- Intermeshing paddles
- Available in sizes from 1500 L to 5000 L or larger
- Seamless integration into high performance and fully automated processing lines
- Service and cleaning platforms
- Infeed:
 - ▶ By lifter
 - ▶ By belt conveyor
 - ▶ By screw conveyor
- Water / brine pipeline filling system
- Outfeed:
 - ▶ Pneumatic covers to 200 L Euro bin
 - ▶ Pneumatic cover(s) to belt conveyor
- Weight registration - load cells
- Siemens HMI's

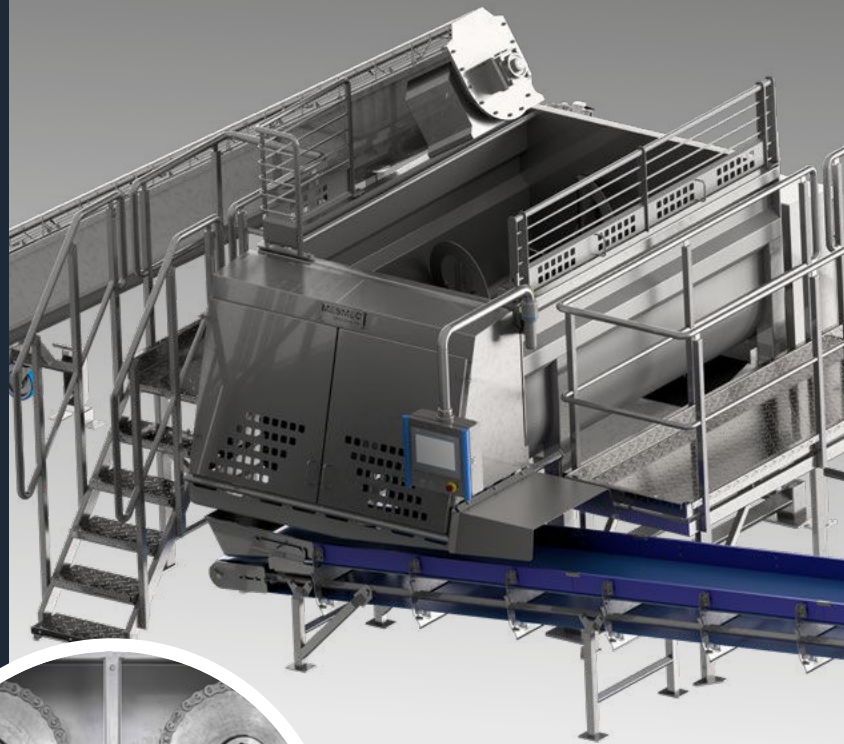

Mixing line solution with
Mesmec OMX Mixer

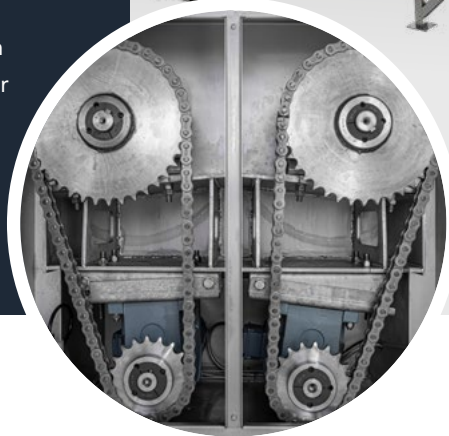

TECHNICAL DATA

Model	OMX 1500	OMX 3000	OMX 5500
Capacity [l]	1,500	3,000	5,500
Maximum load, approx [kg]	1,000*	2,000	4,000
Installed power [kW], double shaft	2 x 7.5 kW	2 x 11 kW	2 x 18.5 kW
Rotation speed of the shafts [rpm/min]	10–30	10–30	10–30
Measures (LxWxH), approx.	3,200 x 1,900 x 2,000	3,400 x 2,100 x 2,100	4,100 x 1,800 x 2,800
Net weight of the machine [kg]	2,400	3,000	3,800
Current protection	3 x 40A	3 x 50A	3 x 80A
Loading options	Lifter/belt/screw conveyor	Lifter/belt/screw conveyor	Lifter/belt/screw conveyor
Unloading options	2 x 200L or belt conveyor	2 x 200L or belt conveyor	2 x 200L or belt conveyor
Discharge covers	Pneumatic	Pneumatic	Pneumatic
Controls	Siemens PLC, HMI 9"	Siemens PLC, HMI 9"	Siemens PLC, HMI 9"
Main electrical cabinet, HD (Hygienic Design)	Standard	Standard	Standard
Required pressure [bar]	min 6	min 6	min 6
Load cells	Optional	Optional	Optional
Water / brine filling system	Optional	Optional	Optional
Intermeshing	Optional	Optional	Optional

* Depending on the raw-material